

KWC MONTA

Trim kit, with safety device DIN EN 1717 – Lever mixer – Tub

Modell-Linie: MONTA | 20.414.550.000

Duschar | Badkarsarmaturer

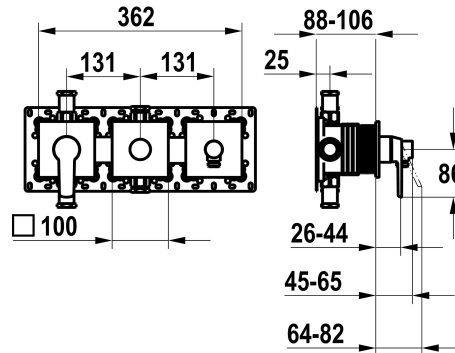

KWC-No.

125336

chromeline, trim kit, with safety device DIN EN 1717

* Trim kit with function unit KWC HOMEBOX

* Outflow

- with integrated hose connection

- above or below for the second consumer with CHOICE diverter without automatic reset

* KWC cartridge M 35-S HF

- with ceramic discs

- flow rate and temperature continuously variable

* Scope of delivery:

- Lever mixer unit

- Diverter unit

- Hose connection unit

- Fastening of the cover plate without screws

* To be ordered separately:

- Unit for concealed installation KWC HOMEBOX Thermostatic/ lever mixer 2 consumers 39.006.261.931

NEW

Technical Data

ATT-KWC-A_ABGANG_UP

19.2 l/min (3bar)

ATT-KWC-A_BRAUSENABGANG

15.2 l/min (3bar)

Diameter

362x100

Handling

frontbedient

ATT-KWC-FARBCODE

chromeline

Installation_type

Väggmontering

Faucet_typ

Hebelmischer

G_Acoustic group

II

ATT-KWC-UNTERPUTZ

FM-Set mit SI

ATT-KWC-G_BRAUSENABGANG

I

EnergyLabelCH

C

Material

Mässing



Reservdelar





KWC MONTA

Trim kit, with safety device DIN EN 1717 – Lever mixer – Tub

Modell-Linie: MONTA | 20.414.550.000
Duschar | Badkarsarmaturer

Cartridge M 35-S HF

537602
Z.537.602
