

KWC

Magazine
Home
Edition 2024

“We’re rolling up our sleeves”

An interview with Urs Tschopp,
General Manager of KWC Home

150 years of KWC

Into the future with
a pioneering spirit

Highlights 2024

Bathrooms,
kitchens and
catering





KWC Stories

“We’re rolling up our sleeves to ensure we deliver only the best” – an interview with Urs Tschopp, General Manager of KWC Home 06

150 years of KWC – into the age of precision mechanics with a pioneering spirit 08

150 years of KWC – milestones of the first 100 years 10

150 years of KWC – innovations of the last 30 years 12

KWC Group – a synergy of expertise 18

KWC worldwide – our references 22

“I’ve been involved with KWC for 20 years” – Andreas Caminada x KWC 28

Flying over the water – Kiel Week x KWC 32

Water for all – all for water – Viva con Agua x KWC 36

Visions have to be lived – in conversation with Michael Lammel | NOA 38





KWC Highlights 2024

	40
KWC in the bathroom	42
KWC HOMEBOX	44
KWC ONO E	58
KWC in the kitchen	72
KWC FIT	74
KWC BEVO E	80
KWC in the catering sector	88
KWC BISTRO E	90
KWC GASTRO E	98
Imprint	106

“We’re rolling up our sleeves to ensure we deliver only the best”

KWC has existed now for 150 years. The company, based in Switzerland, is proud to be one of the few to produce outstanding quality. Since it was founded, the company, which manufactures sanitary fittings, and whose registered offices are in Unterkulm in Switzerland, has frequently adapted to changing needs. To coincide with the anniversary, Urs Tschopp is taking over as General Manager of the KWC Home Division.

KWC Home has a pioneering legacy on the basis of which it has repeatedly adjusted its approach in the last 150 years to cater for a changing future. What are the issues on which the company is currently focusing its attention?

Digitisation across all our business divisions is a key objective. We have made good progress here, but there is still considerable potential for improvement. However hackneyed it may sound to some, sustainability is still high up on our agenda and, in that context, the additional focus on stainless steel as a manufacturing material has been a focal point for us for years.

What exactly do you mean by that?

Almost no other material can claim to be as durable as stainless steel, which is a decisive characteristic when it comes to quality, purity and hygiene.

After all, water is the most important element in our kitchens and bathrooms, so it should be made available by means of fittings that meet the highest standards – day in, day out, reliably and without question.

Urs, you are already General Manager of KWC Home, so you are certainly a familiar face at the company's headquarters in Unterkulm. But now you are taking on responsibility for the Division. What do you see as being of greatest importance there?

Understandably, our main objective is to provide the customer with the best product, the best taps and the best service. Here in Aargau, we never stop in our quest to develop innovations. That is part of our DNA. Our focus on the customer is even more crucial today, since consumers are more able now to access better, more comprehensive information themselves. They are far more aware of what high quality, durability and safety actually mean. We are well placed to deliver on all those factors. The aim is to become even more perfectionist and arouse even more enthusiasm with regard to our products and their uses.

You are known to be the kind of manager that likes to roll up their sleeves and get involved. Where does that come from?





That's an easy one – I'm a qualified carpenter, so I have an eye for craftsmanship and quality. Those are qualities that are essential in that profession. I know how to move around a building site and I've always worked with my hands – I find what I need in the toolbox almost without looking. Of course, if need be, I can fit our KWC fittings myself.

So for you it's always about creating things?

You could put it like that. And I'm convinced I can do exactly that at KWC – one of things I like about working here is the people I work with. The team and their hands-on approach are important factors in my eyes. As market leaders with a long tradition, we have tremendous responsibility.

In the last 150 years, KWC has shown it is highly resilient. We are now faced with a range of crises wherever we look. What's the best approach to deal with them?

I am convinced that it is possible to initiate change in times of crisis. It is possible to get to

grips with things, which can be invigorating. And I do find that people, including our own team here, are prepared to make changes. We have already mastered a range of challenges. What would you expect – after all, we work with stainless steel, as a material, the epitome of resilience.

Is there a personal favourite among the fittings you produce?

Definitely: as an aficionado of good design, my favourite is the KWC ONO: classic, simple, timeless, of premium quality, no fancy bits.

What is your aim at KWC?

I want us to be a strong, reliable partner. We encourage close customer relations and offer capable service. We are also an approachable contact for our trade partners and the individual trades.

Thank you, Urs, for the interview.

Into the age of precision mechanics with a pioneering spirit

The gramophone was to blame. When it replaced the flourishing music box industry at the end of the 19th century, KWC opened up new lines of business. Instead of mechanical music boxes, the company now developed fittings.



In 1874, Adolf Karrer acquired a mill in Unterkulm and began manufacturing high-quality music boxes. Just one year later, the company already had 40 employees, the business was flourishing, a foundry was added, and the technology of the mechanical masterpieces was continually refined until the gramophone conquered the musical world in 1895 and sales of music boxes plummeted. Production ceased in 1902.

Music box

From 1874 to 1902, KWC initially manufactured music boxes – small mechanical masterpieces of precision engineering. The next successful product was the legendary “Gashähni”, a gas tap which was equally successful in luxury hotels and private households.





KWC went on to use its expertise in precision engineering and foundry work to develop completely new, pioneering products, including fittings that were launched on the market from 1897 under the name “Gashähni” (small gas tap). In 1906, KWC presented a fully equipped bathroom, while the factory in Unterkulm was thoroughly modernised: electrical lighting and electric power units were introduced. Less than five years later, KWC was already supplying the luxury Ritz Hotel in Paris with its own line of fittings. In 1914, KWC won a gold medal at the Swiss National Exhibition and already employed 170 staff. The transformation from the music box industry to the fittings industry was complete. From 1919, the speciality fittings company traded as the public limited company Karrer Weber und Cie: KWC.

But who was behind KWC? The founding fathers Adolf Karrer and Eugen Weber, as well as the later partner Walter Luginbühl, were traditional entrepreneurs. Ulrich Weber remembers his grandfather with a “smouldering cigar and elegant watch”, which he “wore on a gold chain in his Giler bag”. As an entrepreneur, Eugen Weber (1862–1949) had a flair for innovation, which led him to travel by ship to America around 1920 to learn about

die-casting technology. After Adolf Karrer’s death in 1895, Weber took over the management of the company. The third member of the team was Walter Luginbühl, Weber’s brother-in-law, who joined the company in 1897 and eventually became his successor as managing director. Grandnephew Ulrich Weber remembers: “His booming voice was unmistakable; he occasionally dined on the train and is said to have entertained the entire dining car.”

Adolf Karrer, Eugen Weber and Walter Luginbühl were doers with a keen instinct for the zeitgeist and shaped the company with their pragmatism: close to the people, with technically sophisticated products and an appreciation for novelty and the opportunities of change, just as their contemporary Joseph Alois Schumpeter (1883–1950) described it, who, as an economist, spoke of “creative destruction” and of “dynamic entrepreneurs” who focussed on innovation and shaped the upswing accordingly.

Pioneering spirit and perfection are still evident today in a large number of patented product developments that continue to shape the way we use water in the bathroom and kitchen.

Negresco Hotel

The elegant single-hole silver tap from KWC not only adorned the flamboyant “Negresco” in Nice, but also the world-famous “Ritz” in Paris.

Milestones of the first 100 years

KWC's innovative strength lies in its ability to combine pioneering technical innovations with perfect design. A brief tour of patents and products that have now become true classics.



1911 Single-hole silver tap

An elegant tap that clearly set apart its components: the curved spout, the locking mechanism and the four-section wing tap were enhanced by the use of solid cast parts. This tap made of polished nickel silver (a copper-nickel-zinc alloy) marked a prestigious commission to furnish two luxury hotels: in Nice (the flamboyant "Negresco" on the Promenade des Anglais) and Paris (the legendary "Ritz").

1954 NEOPERL

The NEOPERL water-saving mechanism, patented in 1954, achieved an incredible reduction of 75 per cent compared to conventional taps. A concealed nozzle gave the water flow a uniform shape and prevented splashing water. In 1959, the ingenious invention and its marketing were transferred to the new Hans Denzler & Co (now Neoperl AG). It was an innovation that is still an integral part of the tap today.

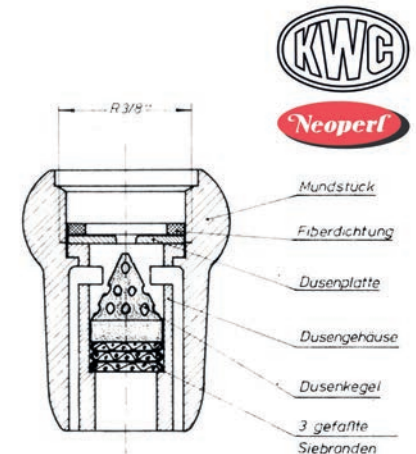

1957 Single-hole kitchen tap with pull-out spray

With its characteristically curved shape, the pull-out spray seemed to be waiting to be put to use. The contrasting black handle indicated where the pull-out could be operated, while the corresponding black push button invited the user to trigger a targeted jet of water with their thumb. This patented innovation, the first single-hole kitchen tap with pull-out spray, was an absolute world first for KWC and opened up a new market segment.

1982 KWC NEODOMO

The legendary KWC NEODOMO lever mixer series soon became the best-selling tap line in Switzerland. With its groundbreaking combination of modern design, pioneering technology and simple function, it marked progress in a natural form – thanks to the ceramic disc cartridge developed in-house. Now a modern classic, the sixth edition still has its finger on the pulse.



Innovations of the last 30 years

Purist design combined with state-of-the-art technology: this is the key to KWC's inspiring user experience.



1997 **KWC TRONIC**

The first automatic tap with infrared technology on the Swiss market sets standards with its sophisticated combination of technology and design.

1998 **KWC INOX**

Forerunner: KWC transforms aesthetic standards and ensures hygiene in the home with the stainless tap in the kitchen.



2001



2005



2002

2001 **KWC SODA**

The tap featuring integrated soda water dispensing directly from the cold water network is a truly pioneering product for Switzerland.

2002 **KWC DISKO**

The first Swiss stainless steel line in the bathroom. The water volume and water temperature are mixed at the same level using a cartridge, enabling the unique design.

2005 **KWC EVE**

Frequently copied, yet never equalled: the world's first retractable and covered pull-out spout, particularly impressive with integrated LED light.

2008



2008

2008 **KWC ONO touch light and lightpin**

Taking innovation to a new level. The DDSA technology (Dynamic Dimension Signal Absorption) means the KWC ONO touch light is switched on by touch. The KWC ONO light pin displays the water temperature visually in the lever and warns you if the water is too hot. Colour gradients clearly indicate the temperature.

2008 **KWC ONO highflex**

Professional quality in the private sphere. The patented spring hose allows the self-supporting pull-out to spring back to its starting position. The operating lever made of medical-grade steel with Diamolith™ coating impresses by being extremely robust and yet light at the same time.

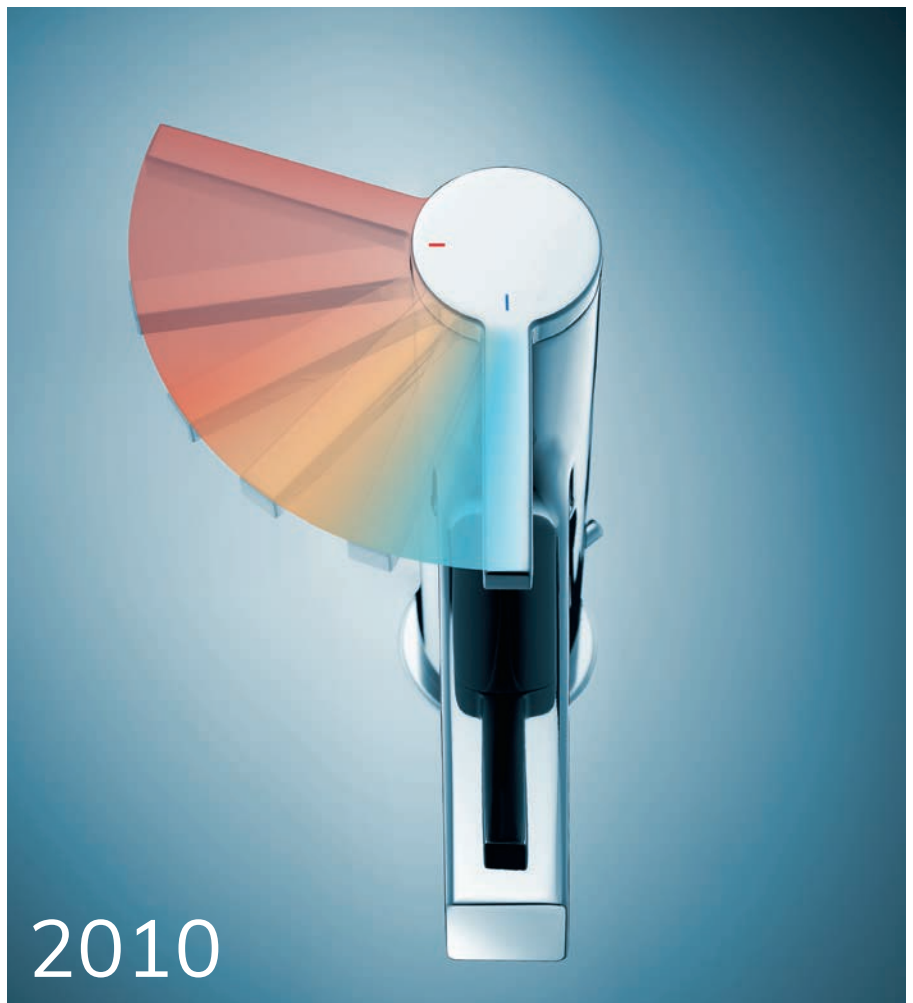

2010



2010 **KWC AVA with CoolFix**
Durability and aesthetics represent what KWC stands for. The specially developed cabrio lever principle allows the lever to float gracefully over the fitting while also being very easy to clean. This special mechanism is still a distinctive hallmark of KWC to this day.

2010 **KWC ONO touchlight PRO**
KWC ONO touch light PRO takes touch light to the next level. A separate operating unit combines all the desired settings (water quantity and water temperature). Another milestone in the digital control of fittings.

2015 **KWC ZOE touch light PRO**
The unique KWC ZOE gets an electronic upgrade and becomes a multi-award-winning style icon. The integrated touch light PRO control directly at the base of the tap takes user friendliness to a new level.



2018 **KWC ERA**

Iconic design: a revolutionary stainless steel forming process makes KWC's slimmest stainless steel tap possible.

2021 **KWC AVA E**

Hygiene in the bathroom: the KWC AVA E stainless steel range captivates with its easy operation thanks to the cabrio lever principle, slender proportions and true architectural clarity.



2021



2022

2021 **KWC DOMO E**

The Swiss classic makes its debut in stainless steel. With its perfect transitions, the tap body is created using the stainless steel investment casting process. A stainless steel tap body made from a single cast.

2022 **KWC KIO**

Everything in one hand: KWC KIO combines the demands of a professional kitchen with electronic control. Maximum ease of use paired with electronic sophistication.

KWC Group – A synergy of expertise

Our product families are designed with the future in mind. Only when design, technology, innovative thinking, material knowledge and manufacturing expertise come together can real added value be created. And tangible comfort. The perfect combination of wide-ranging expertise is a tradition at KWC.



Stainless steel Durable perfection

Modernity has been shaped by many different materials, but stainless steel is still in a class of its own with its robust, highly aesthetic surfaces. It can be almost completely reused, which means we contribute to a circular economy through durable, recyclable products. For us, stainless steel is more than just a material. It is a building block that is not just of great importance for the food processing industry, but also offers unbeatable advantages for private use, including minimal heavy metal release in drinking water, hygiene (with virtually no breeding ground for bacteria) and exceptional aesthetics with long-lasting durability. A premium material for premium quality.

Design

Swiss craftsmanship

Our design has been characterised by precision, elegance and architectural style since the very beginning. With our fittings, we have been committed to enriching the quality of life of every individual for decades. Forms and functions must be brought together in harmony. In our quest for perfection, the individual always takes centre stage. This aspiration motivates us to create the best products of their kind.



Electronics

Sophisticated control

Modern electronics enable users to save personal preferences and change settings with ease. An electronic control system ensures maximum precision in controlling water flow and temperature. As KWC, we play a pioneering role in this field with our innovations, such as touch light PRO technology and new intuitive control systems. We are committed to continually perfecting technology for people. Safety, ease of use and ecological efficiency are always at the forefront of this process.



Innovation

Progress you can experience

The pioneering spirit is firmly anchored in our DNA. Whether the invention of the pull-out spray, the reinterpretation of the spring hose with the patented highflex technology, innovative and unique designs or the integration of electronic controls: people and their needs in the future are what constantly drive us to innovate, which is reflected in a large number of patents. The new is not an end in itself. Our aim is to achieve the perfect symbiosis of design and captivating user experience: convenience thanks to intelligent technology, precise control and high-quality design. That is quality of life for us.

Hygienic drinking water

Our purity requirement

There is no quality of life without hygienic drinking water. We therefore do everything we can to ensure and exceed the high requirements for clean drinking water. It's no surprise that we develop state-of-the-art manufacturing processes, use high-quality materials and always go one step further: premium stainless steel fittings paired with electronic control as well as our high quality standards and continuous testing. This is how we set new hygiene standards.



Water conservation

Responsible use of resources

Water is one of our core elements of life and perhaps the most valuable resource that needs to be protected. With our water-saving options, featuring EcoProtect or CoolFix technology, we have been committed to conserving water and using this resource sparingly for years. Reducing water consumption is the result of many small steps. With KWC's solutions, we want to do our bit to make it as easy as possible for everyone to integrate the sustainable use of water into their everyday lives.



KWC worldwide – our references

The world of construction is in motion. Exceptional projects show that modern architecture and longevity complement each other perfectly. The key to this is durability and quality. This is why renowned interior designers/architects and property developers are enthusiastic about premium products from KWC. Allow us to take you on a little trip around the world.



Nordic Villa

The eye is drawn to the greenery and is lost among the beech trees and their radiant autumn leaves. On the outskirts of the Norwegian town of Skien, the country's most important timber producer since the 15th century, you will find a minimalist villa furnished in the Nordic style. Durable materials characterise the house with its concrete framework and cladding made of maintenance-free thermowood (awarded the Skien Architecture Prize 2021). Its centrepiece is an open-plan kitchen with a dining area for the whole family. The kitchen island is made only of wood and stainless steel. The welded-in sink is crowned by the KWC ERA with soap dispenser, perfectly rounding off the no-frills architectural style.



**NORDIC VILLA |
SKIEN, NORWAY**

Architects: Feste Landscape/
architecture by Lars Haakanes

KWC ERA | Kitchen



Park Hyatt Auckland

New Zealand's Bossley Architects designed the Park Hyatt Auckland as a shimmering jewel on the waterfront, a seven-storey, five-star hotel with 195 rooms, four restaurants and bars as well as a swimming pool and rooftop bar. On the exterior, the building echoes the harbour's shipyards, while a large atrium connects the rooms on the inside. As you would expect, the architects have opted for natural ventilation and PV panels on the roof as well as charging stations for electric vehicles and bicycle racks. The high standard of the house is reflected in its fixtures. Selected Māori artists and carvers have shaped the interior design, while the professional kitchen has been equipped with KWC GASTRO fittings.



PARK HYATT AUCKLAND | AUCKLAND, NEW ZEALAND

Architects: AR+D / Bossley Architects

KWC GASTRO | Catering



	SCHLOSS SCHAUENSTEIN FÜRSTENAU, SWITZERLAND
	KWC GASTRO Catering

Schloss Schauenstein

It is rare to find such an exclusive blend of history (a castle from the 17th century), spiritual site and culinary seduction (three Michelin stars), which KWC brand ambassador Andreas Caminada has held for years. In his boutique hotel with just nine rooms in two separate buildings, there is no such thing as coincidence. Everything here is to the point, just like it is on the plates of his Michelin-starred restaurant. Andreas Caminada makes no compromises in the kitchen, which is why he has opted for the professional catering line KWC GASTRO for his fittings. The Michelin-starred chef swears by the uncompromising premium quality of the fittings: extremely robust and durable. Off to the Grisons.



**KAJAK POINT HOUSE |
STANWOOD, WASHINGTON, USA**

Architects: Christopher Wright Architecture

KWC SIN | Kitchen



Kajak Point House

A retreat on the picturesque Puget Sound, almost exactly halfway between Vancouver and Seattle. The house is set amidst a grove of old cedars and overlooks the water. To protect the trees and their roots, two steel girders span the ground so that the house itself appears to float above the forest floor, completely without foundations. The result is a retreat in the style of the legendary Eames House, meticulously designed down to the last detail. Our KWC SIN tap matches the clean lines of the kitchen.

“I've been involved with KWC for twenty years”

Swiss three-star chef Andreas Caminada set up his own business early on. Today, he is a star at the gastronomic summit. And an entrepreneur who, even after twenty years of success on his own, is not resting on his laurels, but constantly reinventing himself. Like KWC, he is also now celebrating an anniversary.

With Michelin-starred cuisine in Schloss Schauenstein, your vegetarian restaurant Oz in the neighbouring coach house, the permaculture castle garden and Casa Caminada offering regional cuisine. Andreas, you rule your gastronomic realm from Fürstenau, the smallest town in the world, as they say. Today, this is the foundation of your growing gastronomy business. We would like to sincerely congratulate you on your anniversary.

Yes, we have been able to build something over the last twenty years, that can be said in all modesty. That's how long we've been around, because I decided early on to become self-employed. Despite my perhaps youthful recklessness and the enormous amount of heart and soul I put into it, I would never have dared to hope that it would work out like this. Two decades have passed since then and now is the time to reward ourselves.

Can you tell us what that looks like? Will there be any surprises?

We decided not to have a big party to mark the occasion, but to give our guests presents instead: We are refurbishing the rooms in the hotel and the restaurant in Fürstenau. The restaurant already shines in new splendour and the rooms from March 2024. And since 5th December 2023, we have been running a year-long series of surprises here with us. So we are celebrating this birthday together with our guests.

Running a fine-dining restaurant is like a high-performance sport. You have proven yourself and are known for keeping a cool head even in stressful situations. This is paired with a lightness; a certain coolness.

Thank you, of course I'm delighted if that's how it's seen. I try to embody the culture of an uncomplicated local host. Because one thing is important to me: Our guests are the most important I endeavour to do my best for them every day: I want them to be surprised, I want them to feel comfortable with us, I want them to experience something extraordinary. It's the





same as with KWC. They focus on offering their customers the best product and the best experience. That is an aspiration that positively motivates and drives you. And I also believe in consistency. The best example of this is that right when I was starting out as a young chef, I had my first KWC fittings. And then there were more and more. So I've been involved with KWC for two decades.

So there is already a certain heritage. This is a value that also plays a major role for KWC, which is now celebrating its 150th anniversary.

History and background provide the fertile ground needed for everything. My own heritage is nowhere near as long as that of KWC (laughs). 150 years is a huge history, you have to achieve that first. And yet there are parallels: Quality and continuity, highs and lows – just like us. I have learnt a lot in my career, I have always developed further and looked to the future. You also have to take risks from time to time to maintain the tradition.

Why did you choose KWC products?

Well, KWC is not only the market leader in the catering fitting segment. They are also a byword when it comes to quality and stainless steel. And that is a must in the professional kitchen. It is durable, with a clean, minimalist ambience and extremely robust. In terms of ergonomics, it's important to me that I can operate the tap with one hand, for example to fill a pot. When rinsing, I need a water sprayer with a flexible and reliable arm and high flow rates.

Does hygiene also play an important role in your gastronomy business?

But of course, it should not be underestimated. The hygiene factor is extremely important for us. For example, to keep the drinking water clean through the functions of the individual fittings. Hygienic stainless steel is also the ultimate for private kitchens, which is why I also have them in my home. I have to be able to rely on them. When it comes to quality and safety, I am absolutely uncompromising.



What role does water actually play as an element in the kitchen – from a professional's point of view?

Nothing is possible in a kitchen without water, it's basic element number one – and not only when preparing food, but also to maintain hygiene standards, wash your hands and keep workstations clean at all times. The tap is a fundamental piece of equipment, I have to be able to trust it to do its job: it must work ergonomically, quickly and routinely. Otherwise, it's simply a hindrance in a demanding star-rated kitchen.

What does water mean to you personally, you're said to be a nature lover ...

Yes, and from this perspective, water is also an element that offers many different experiences. We all know what it's like to be thirsty, to long for a dip in a lake or the sea, or to enjoy a cold shower. Water appeals to the senses and is an ingredient in many of our recipes – just think of sauces and stocks.

What's currently on your mind, a matter that is particularly concerning or motivating you at the moment?

In addition to the pursuit of perfection, it's actually sustainability, even if that's virtually become a buzzword nowadays. For me, this simply means what I internalised early on in my apprenticeship: you don't throw anything away. That's something I've learnt, and I didn't

just start spreading the message today. We don't want to be wasteful, we have our own little diversity in our "vegetable system", we even roast our own espresso. It's like a small eco-system of its own in Fürstenau. In other words: local, from here, with suppliers from the region.

The topic of supporting young talent is something very close to your heart.

How can one become as successful as you, what can young chefs learn from you?

It takes grit and passion for the job, the dream of achieving something. That's indispensable, no matter how good your technical skills are. It always sounds so easy, but it's a lot of hard work to consistently do the right things over the years. You need time and patience to succeed. Of course, I can only speak for myself. The restaurant trade is my passion, I knew that early on. I'm grateful that I discovered cooking for myself. That's what I wish for others too, especially young people.

You have achieved so much. What does cooking still mean to you today, after all these years?

Today, it's my everyday life. My regular guests motivate me, I cook with the seasons and experiment with new dishes. There's also a certain natural pressure in me to keep challenging myself. We're flying high and have top standards that must be upheld. I see it as

a team sport, we have positive energy and drive. I'm happy when the guests are happy, that motivates me. I'm just always on the go. Innovation is my engine.

That sounds like true passion. But as a business owner, you also have a lot of responsibility. How do you handle it?

The biggest challenge is juggling everything, to keep on top of it all. Personal commitment is crucial: I handle the many bills, the comfort of the guests, I'm there for our employees and I'm also responsible for the products we use. And I have to make a lot of decisions. We are a family business, that's for sure. And we have learned a lot. Everything is running smoothly now, but you have to keep at it. You are a psychologist, controller, coach, motivator and, of course, host. You have to meet everyone's needs, and you have to keep your feet on the ground, live a healthy life, be diligent, disciplined and professional.

And do you have a way to unwind? As a Swiss individual, you probably love heading into the mountains.

Yes, of course, with my children. And I enjoy football. When I get the chance, I love to go to the golf course in the evening to play a few holes, alone, just for myself.

And do you then return with fresh ideas? Can you tell us whether there's anything in the pipeline?

In addition to the existing IGNIV restaurant – the Rhaeto-Romanic word for nest, by the way – another one will be opening in Andermatt in late 2024. The project is well under way. We are opening a sharing restaurant in the new Andermatt Reuss neighbourhood. This is set to become a new beacon of outstanding gastronomy in the Swiss Alps. The town is developing tremendously and promises extraordinary experiences. It's very exciting for us to be a part of this. And last but not least: I will also be publishing a new book, featuring fish recipes from my past.

Thank you, Andreas, for the interview.



Flying over the water

The sailors Maru Scheel and Freya Feilcke took second place at Kiel Week. Here they talk about their special relationship with perhaps our most important resource.

For many, Kiel Week is not just an event, but something very special, what about you?

MS: It takes place at home, in front of our friends, in front of our family. That is very special.

FF: We both sail in the Kiel Yacht Club, and we like the Kiel Fjord because it offers our favourite sailing conditions. We know the wind, the waves and feel we are the fastest there. That's why it's always so nice. But this year was very special.

Because you came second in the Olympic FX boat class (in the 49er FX)?

FF: Yes. And we did it on our home turf.

In the end, there was only one point in it.

MS: We went into the last race, the medal race, in fourth place. Points count for double.

FF: Fortunately, we did really well there. If we had been just one boat further ahead, it would have meant victory, but we were happy as it was. It was a great feeling.

The forces acting on the boat can only be guessed at from pictures. What does a race like this feel like?

MS: I would say that we sail one of the fastest and most sporty boat classes.

We practically fly over the water with our whole body, which feels incredibly beautiful and strengthens our connection to water, wind and the elements because we experience everything up close.

FF: We have a special class of boat, everything is relatively action-packed, especially when you're really fast. Then it's a lot of fun.





Do you need an adrenaline rush?

FF: Of course. That's why we decided on this boat class.

MS: It's fast, competitive and working in a team is cool. We've been sailing together since 2017. I'm the helmswoman, I have the rudder in my hand and I tend to say which way to go – and Freya makes the boat go fast. She controls the sails and trims the boat so that we fly over the course.

How did the roles come about?

FF: It's typical that the helmsman takes care of the strategy and tactics and I'm responsible for the athletic part, trimming the sails and speed. And that worked quite well for us right from the start.

What still stands between you and the European Championships?

FF: Actually only one training camp and a training regatta. In sailing as in everything else: The preparation is crucial, the material and the experience that builds up over time.

Which do you need? Luck, good preparation or mental strength?

MS: Everything has to come together.

FF: A little bit of luck probably always helps, because you can't foresee everything. But in principle, it's about experience. Sailing is a sport that relies on experience. You can feel the refinement that is added when you sail longer.

And your big goal after the European Championships?

FF: The 2024 Olympic Games. We travel all over the world and train with international female athletes who we meet everywhere. This is how we measure ourselves against the best.

Perhaps our most valuable resource is water.

MS: We love water. Through our sport, we have a very special bond with water because it is the main element we work with.

FF: Pollution of the world's oceans is a major problem that we feel directly during competitions.

Because there is so much rubbish floating in the sea?

MS: Yes. Plastic in the water hinders us as sailors. But all in all, it is devastating for the planet. This has many more effects than just on our sport.

What is your view of water and sustainability in general?

MS: It's a huge topic. We mainly sail on salt water. But what comes out of our taps is precious fresh water. And we should be careful with that. We learnt as children not to waste water. As a team, we therefore pay close attention to how we use resources overall.

FF: We should keep the big picture in mind. Sustainability also means that we have to change our behaviour, waste less and become aware of how important clean water is.

Kiel Week is supported by KWC.

MS: For the first time, there were over a dozen drinking water fountains in the city and on the Olympic site in Schilksee, sponsored by KWC. These are important because otherwise everyone drinks from disposable plastic bottles at sailing events. This saves a lot of plastic and contributes to sustainability efforts.

FF: And we had the privilege of sailing a 49er FX from KWC. It's great to represent a company that stands for quality and sustainability and is committed to providing people with clean drinking water.

We hope you have fair winds!





The biggest sailing event in the world

Over three million visitors come to the Kiel Fjord every year for the largest sailing event in the world: Kiel Week.

We have been supporting Kiel Week as a partner since 2023, emphasising our affinity with the water. As an international premium manufacturer of fittings and comprehensive sanitary solutions, we are all about perfection – just like in sailing. In other words, high, even the highest standards for products, materials and traditions. We strive for optimal solutions with professional passion.

Water for all – all for water

KWC and Viva con Agua share a common mission: to improve the quality of life of people worldwide through access to clean drinking water and to raise awareness among the general population for the responsible use of this vital resource.

The situation is dramatic: over 700 million people worldwide live without safe access to clean drinking water, while over 1.5 billion people have no access to basic sanitation at all. The international network “Viva con Agua” wants to change this and therefore supports drinking water and sanitation projects worldwide.

Since its foundation, Viva con Agua has been able to realise projects for a total of 3.8 million

people together with numerous project and financing partners. The organisation focuses on innovative corporate events and creative activities in music, art and sports and relies on donations from private individuals and companies. These are mainly channelled into so-called WASH projects. WASH stands for access to clean drinking water, basic sanitation and hygiene education. This three-pronged approach guarantees the long-term and



KWC is part of the Social Business Club

KWC in the innovative corporate network of Viva con Agua. The Social Business Club is an opportunity to expand your professional network, support drinking water projects and take part in exclusive events.



sustainable success of the individual project measures, which are always put into practice together with the local population. The idea of the ALL PROFIT organisation and putting the fun into fundraising has become an international idea and is making the vision 'Water for all – all for water' a reality!"

"With Viva con Agua, we are committed to providing all people with access to clean drinking water, sanitation and hygiene facilities. Achieving this goal requires strong partnerships. We are proud of our partnership with KWC and are delighted with the company's wonderful, impactful commitment."

Gregor Anderhub, Founder, Viva con Agua Switzerland

KWC is also enthusiastic about the Viva con Agua organisation and supports its social and sustainable commitment.

"Sustainability and hygiene have always been an essential part of our identity.

The responsible use of water is very close to our hearts. That is why we ensure sparing consumption of this precious resource with our wide range of sustainable products and technologies. When it comes to hygiene, we also make a significant contribution with our products: the protection of health and access to hygienically clean drinking water are essential requirements for the development of

our products. That is why we only use high-quality metals and plastics.

Viva con Agua is a perfect partner for KWC, as the organisation shares our values and translates our commitment into tangible projects. We look forward to working together as a Social Business Club member and to many exciting projects."

Urs Tschopp, General Manager KWC Home

"Christmas for Mozambique" was the first campaign organised by KWC and Viva con Agua as part of their joint mission for clean drinking water. With the sustainable drinking bottles from Viva con Agua as a customer gift and the associated fundraising campaign, KWC is setting an example for the conscious and careful use of water as a valuable resource.

With this initiative, KWC and all other partners are supporting the construction of new water supply systems in Mozambique. The project furthermore has a strong focus on improving hygiene and also aims to expand and improve training and further education opportunities for authorities, operators, tradespeople and water committees so that the water supply can also be maintained and repaired independently of development organisations. In addition, basic sanitation is being expanded in schools and health-conscious lifestyles are being promoted through hygiene workshops. Thanks to the overall project, 50,000 people in six districts within the Cabo Delgado and Nampula provinces in northern Mozambique benefit from access to clean drinking water, sanitary facilities and greater hygiene awareness.

Become part of the water project and make access to clean drinking water possible with your donation.

Visions have to be lived

How can you design water conservation? And how far do the designers look ahead? Interview with Michael Lammel, visionary and strategist at the renowned design agency NOA.

You have been working successfully with KWC for 20 years. What's your secret?

There isn't one (laughs). The key point is that we are trying to develop the programme consistently in a changing context.

You rely on simple geometries. The KWC ONO essentially consists of just a cylinder and a pipe.

We took the lead early on. We were and are all about precision, about interfaces between the individual elements; our geometric standards are aligned with modern architecture. We love high-precision transitions and perfect proportions. In a way, we are striving for the archetype of a tap, perfect in function and appearance. A durable, simple form.

Perfect for an increasingly complex world.

We are the ones who, together with our customers, try to understand what will happen in the coming years. Exploring future scenarios is my favourite field. We do this by developing ideas based on trends: what will the situation look like in five years' time? What does that mean for a company? And specifically for buildings, people and products?

So the real challenge is not to design an eye-catching fitting, but to recognise trends at an early stage and take a stance on the issue of water scarcity, for example?

Design has long been more than just product design, even if expressive styling remains our goal. We look further ahead. In a first

step, we analyse needs and requirements. Ultimately, it is about all three levels: planet, people, technology. And thus the question of which developments have a global impact on society. We have already felt the effects of the water situation in recent years, ...

... sometimes there were droughts, then floods ...

... right. For developers, this means that we address the issue because it affects all customers.

That's why it's all about saving water and sustainability in general.

Absolutely. My first priority are customers and their needs. At the same time, we also set ourselves high standards when it comes to saving water and the materials we use. At KWC, we focus on using stainless steel, which is both hygienic and sustainable, as a large proportion of it is already recycled. Moreover, stainless steel doesn't need to be chrome-plated. With the KWC development team, we want to think about five years ahead. And when you do that, there's no way around sustainability.

How can you design water conservation?

Water conservation itself has largely been exhausted technically. Nevertheless, we'll keep going. KWC, for example, has a so-called Choice function. This is also installed in current exposed and concealed thermostatic mixers. This button allows me to keep the

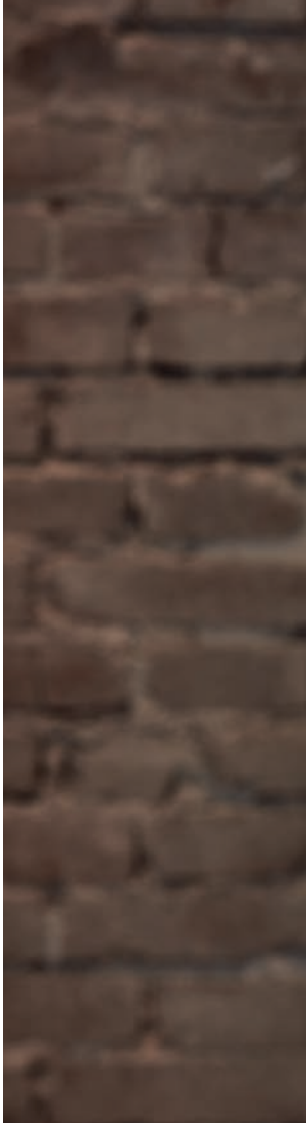



water flow at a certain preset temperature, lather up and then continue showering at the same temperature. A very simple solution. We do of course realise that this innovation alone is not enough. KWC is always committed to sustainable and credible further development.

We experience the bathroom as a wellness oasis. What developments do you see?

Well, when you talk about wellness, about well-being, it's about an attitude towards life. Solutions should give you the freedom not to have to think about how to control the water. But to have some headspace and maybe linger on the dream you had last night. We shouldn't over-engineer the bathroom, but find high-quality and easy-to-use solutions. The same goes for everything digital.

Does that also apply to the kitchen?

Here, too, we are constantly evolving and offer a wide range of digital solutions. The electronic version of the KWC KIO tap has a functional control element: "cold and hot water" and a clear "start-stop" display that can be controlled directly when the spray

head is in use. Not only does it look good, it also saves time and water, just like the Eco-Protect lines with their low flow rates.

So how do you see the future of the kitchen and bathroom?

In both fields, KWC will be looking closely at sustainability and integration into smart building technology as well as the question of what users will demand of fittings in the future and beyond. Finding the perfect balance here and offering solutions is part of KWC's future scenarios.

Bathroom and kitchen differ here: in the shower, it's all about having space to think, intimacy and well-being, which KWC fittings fulfil. Modern, sustainable technology is integrated discreetly. The focus is different in the kitchen, where the fitting is a tool. The question here is how the kitchen will develop in the context of the domestic environment and how we will prepare food in the future. The fittings are increasingly becoming the chef's assistant and deliver performance with the help of modern technology. Physically and digitally. Professionals also demand that their products work particularly well for a long time. At KWC, we work on precisely this perfection and on ensuring that our solutions last.

Then there is still plenty to do for the next 20 years with KWC.

Certainly. Our creative, dynamic designers and developers are interested in the task and the context: planet, people, technology, which we mentioned at the beginning. KWC is embracing this transformation. That definitely keeps the task exciting for us.

Michael Lammel, thank you for the interview.





KWC Home

Taps to make a statement



The bathroom as an oasis of well-being

Recharging your batteries, taking a break, or making a quick and easy start to the day: Where, if not in the bathroom, do well-being, relaxation and refreshment come together in perfect harmony?

That's why the fittings for washbasins, showers and baths deserve special attention. KWC sets glamorous accents with a sleek stainless steel design, intuitive operation and easy-to-install solutions.

Convenience meets aesthetics

KWC HOMEBOX – strikingly simple and versatile, the universal concealed solution for any bathroom size.

The range of compact concealed solutions features a wide variety of products and allows for extremely simple installation. Products in this line can be combined in a variety of ways, from a simple shower situation to a complete thermostat system with two outlets in different surface colours. The various functions can be easily selected at the touch of a button. KWC HOMEBOX, the innovative solution for the stylishly minimal design bathroom.





KWC HOMEBOX

Modularity for versatility in application

Universally suitable

With its modular design and specific functions, the KWC HOMEBOX is the ideal universal concealed system for any application.

Modular concept

Lever or thermostatic mixer, single or dual outlet: the modularity of the components enables the system to fit seamlessly into the KWC product lines.

Thermostatic mixer

Dual outlet

Overhead and handheld shower head*

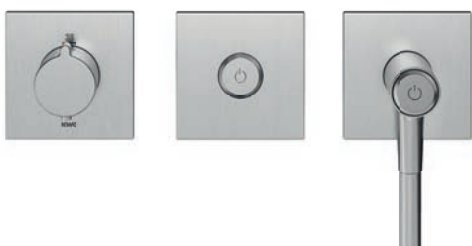

Single outlet

Handheld shower head



Lever mixer

Dual outlet

Overhead and handheld shower head*



Single outlet

Handheld shower head



Module 1
Lever mixer



Module 2
Switch overhead and
handheld shower head*



Module 3
Hose outlet
Handheld shower head



Module 1
Thermostat
with temperature
setting



Module 2
On/Off
Overhead shower or
bath spout



Module 3
On/Off and
flow setting
Handheld shower head



Module 1
Thermostat
with temperature
setting



Module 2
On/Off and
flow setting
Handheld shower head



*bath sprout and handheld shower head also possible

KWC HOMEBOX

Intuitive operation

Safe use

Safety as standard. The hose outlet is secured against backflow in all variants in accordance with DIN EN 1717. A shutoff prevents possible scalding on all thermostatic mixers and the water temperature remains constantly below the critical value, even if the cold water fails.



Comfortable operation

As simple as a light switch. The water starts flowing when you press the Choice control button and stops when you press the button again. The water flow can also be precisely regulated on all thermostats using the control button.

Press

Save water and energy when lathering up. The water flow can be stopped immediately at the touch of a button and restarted just as quickly.



Turn

Water flow under control. Turn the Choice button to precisely regulate the flow rate. The hose outlet is directly integrated in all versions.



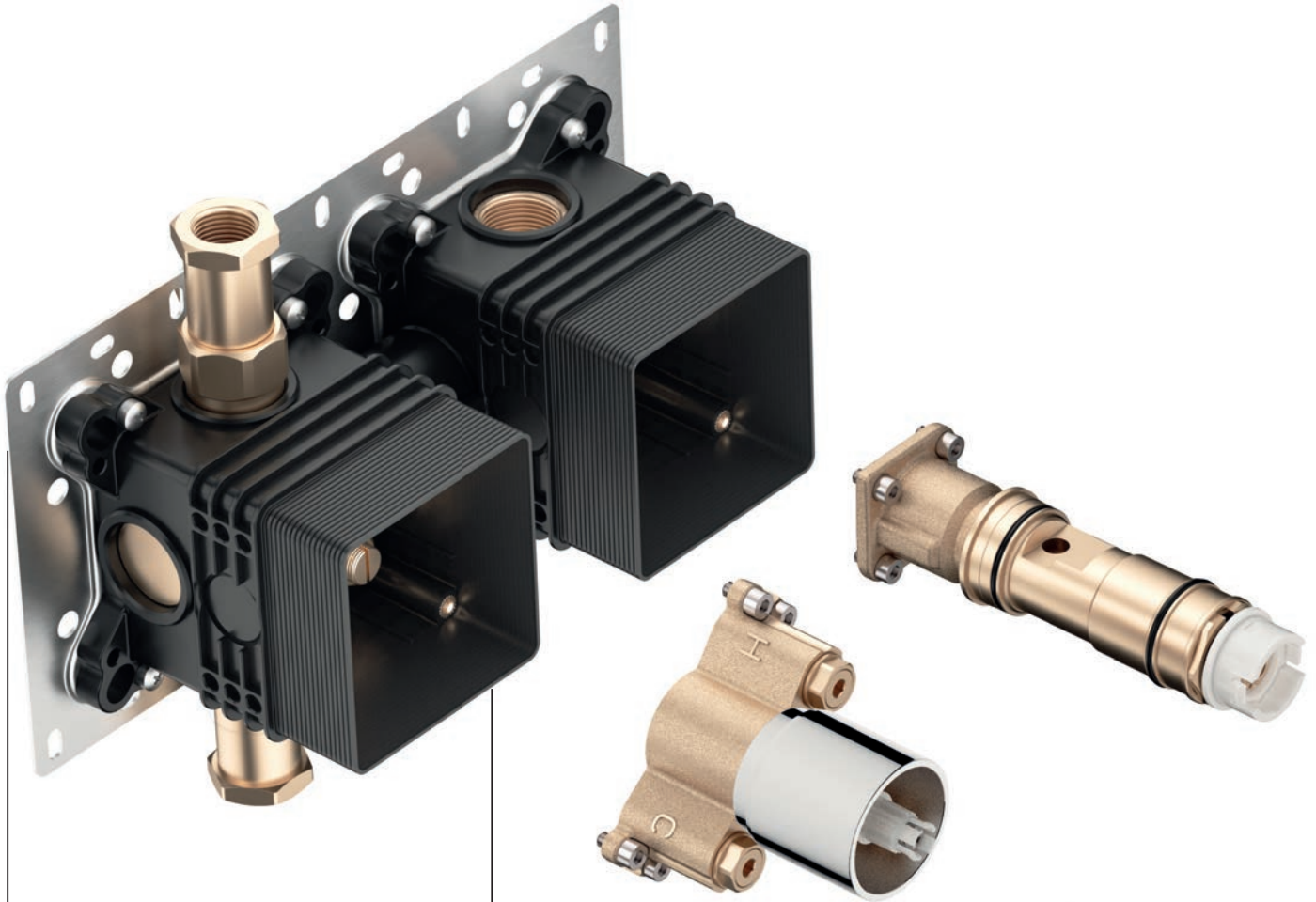

Precisely positioned

It couldn't be simpler: the mounting rail for the boxes can be easily attached to the surface with millimetre precision.

Supplied pre-configured

Ready to use – the modules of the set are already connected to each other. Guaranteed easy alignment and installation thanks to pre-assembled boxes.

KWC HOMEBOX

Easy installation and assembly

Quickly attached

Super simple – screws secure the escutcheon holders firmly to the box and prevent splash water from penetrating.

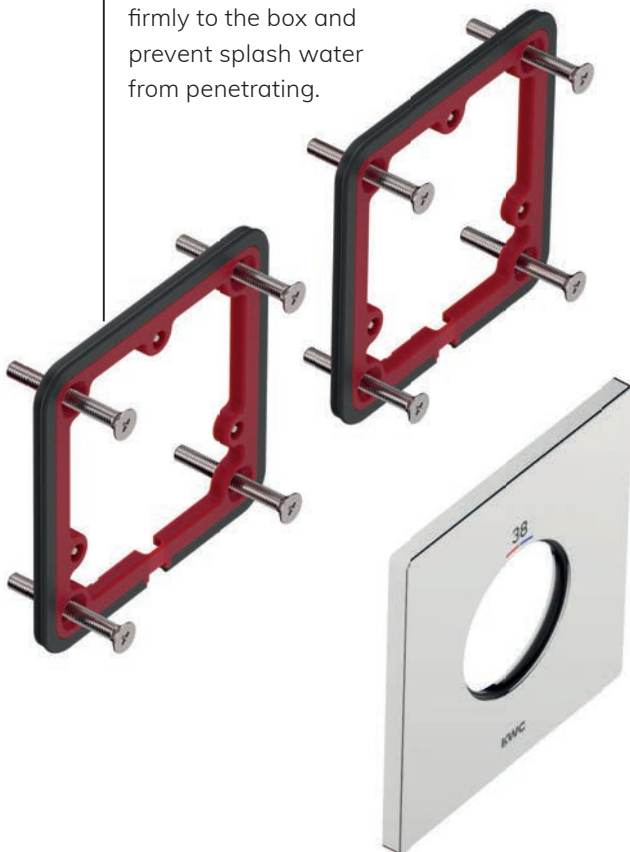

Smartly mounted

Time-saving – the escutcheons are attached to the escutcheon holder without a single screw.



Compact dimensions

Effortless – the minimal projection of the operating units leaves plenty of space for installing the fittings, for example in narrow shower cubicles.

KWC HOMEBOX

Twice the talent

Masonry

The mounting rail is ideal for shell construction. It allows the box to be perfectly positioned and easily aligned.



Drywall construction

Retaining rings on the boxes mean that the KWC HOMEBOX can also be easily and securely attached to partition walls.



Safety

If the hot and cold water inlets are installed incorrectly, the water flow can simply be reversed. If the box does not sit in the wall at the required installation depth, this can be quickly corrected with the extension sets.

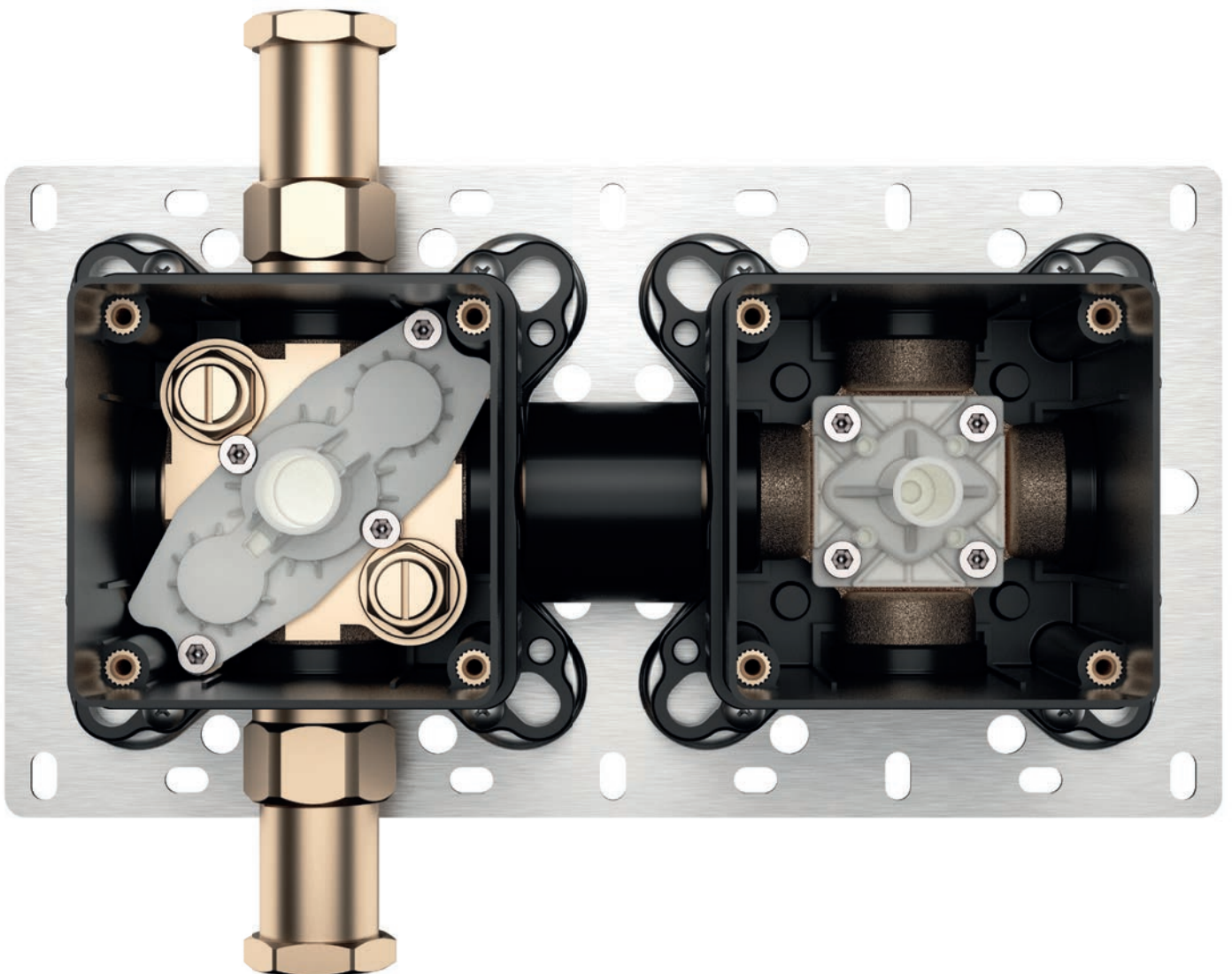



Trim kit
single outlet
KWC ACTIVO

125332, chromeline



Trim kit
single outlet
KWC AVA 2.0

125289, chromeline



Trim kit
single outlet
KWC BEVO

125291, chromeline



Trim kit
single outlet
KWC DOMO 6.0

125290, chromeline



Trim kit
single outlet
KWC ELLA

125292, chromeline



Trim kit
single outlet
KWC FIT

125434, chromeline



Trim kit
single outlet
KWC MONTA

125333, chromeline



Trim kit
single outlet
KWC WAMAS 2.0

125334, chromeline



Trim kit dual outlet Choice
KWC ACTIVO

125335, chromeline



Trim kit dual outlet Choice
KWC AVA 2.0

125293, chromeline



Trim kit dual outlet Choice
KWC BEVO

125295, chromeline



Trim kit dual outlet Choice
KWC DOMO 6.0

125294, chromeline



Trim kit dual outlet Choice
KWC ELLA

125296, chromeline



Trim kit dual outlet Choice
KWC FIT

125435, chromeline



Trim kit dual outlet Choice
KWC MONTA

125336, chromeline



Trim kit dual outlet Choice
KWC WAMAS 2.0

125337, chromeline



Trim kit
Thermostat single outlet Choice

- 125297**, chromeline
- 125298**, matt black
- 125299**, brushed steel



Trim kit
Thermostat dual outlet Choice

- 125300**, chromeline
- 125301**, matt black
- 125302**, brushed steel



Trim kit shower holder

- 125303**, chromeline
- 125304**, matt black
- 125305**, brushed steel



Base unit 1/2" single outlet – with shutoff valve

125286



Base unit 1/2" single outlet thermostat – with shutoff valve

125288



Base unit 1/2", dual outlet – with shutoff valve

125287



Pure stainless steel aesthetics

KWC ONO E – stainless-steel fittings in delicate perfection for the premium bathroom.

Slimmer than any other KWC bathroom fitting. Clear lines, high-quality materials, refined down to the last detail and a pleasure for all the senses: the quality of the design matches the quality of the construction. The KWC ONO E is made of pure stainless steel with a brushed or chrome-plated surface, which together ensure complete hygiene. The sleek design is complemented by the durable construction – a tap that adds a brilliant touch to any premium bathroom.

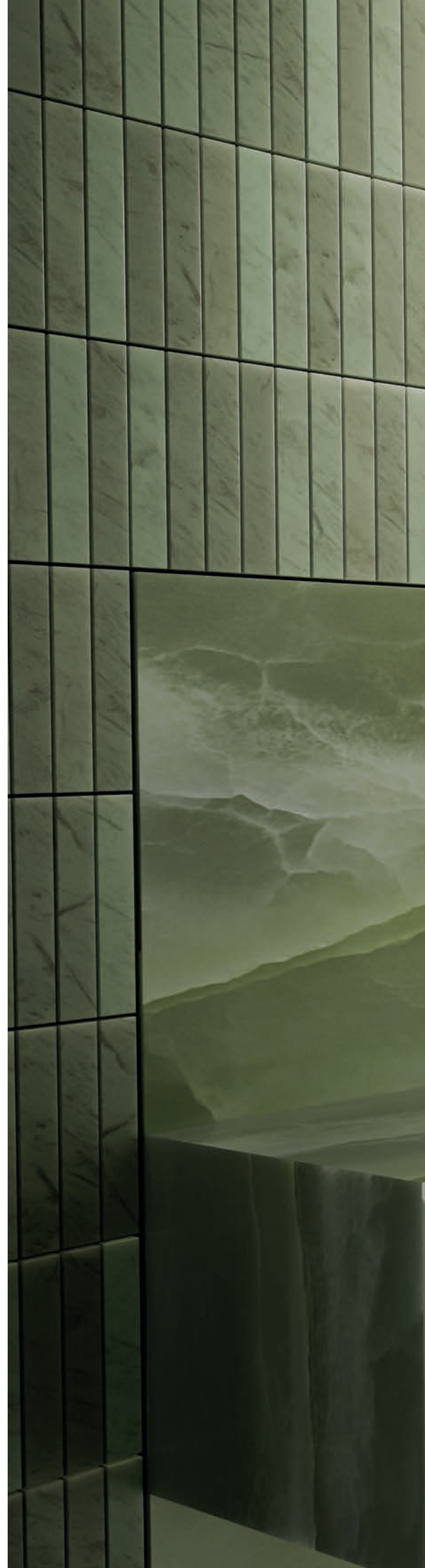



KWC ONO E

Understated elegance

Beautiful in detail

The radial brushing emphasises the curved character of the tap. The fine workmanship and minimal gap widths are also testament to the attention to detail. This makes even the largest version appear light and elegant. A timeless design.

Effortlessly sleek

The KWC ONO E in stainless steel is already a design classic, and with a diameter of 35 mm, slimmer and more elegant than ever before. Whether with a chrome-plated or brushed finish, this is a stylish premium product from the KWC brand.





Delicate throughout

The operating lever does not require a recess. Slightly bevelled surfaces on the lever and spout emphasise the airiness of the design.

KWC ONO E

Functional purity

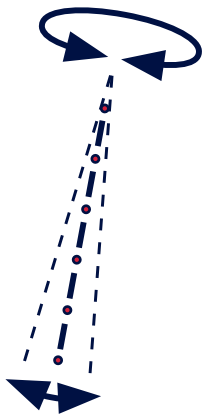
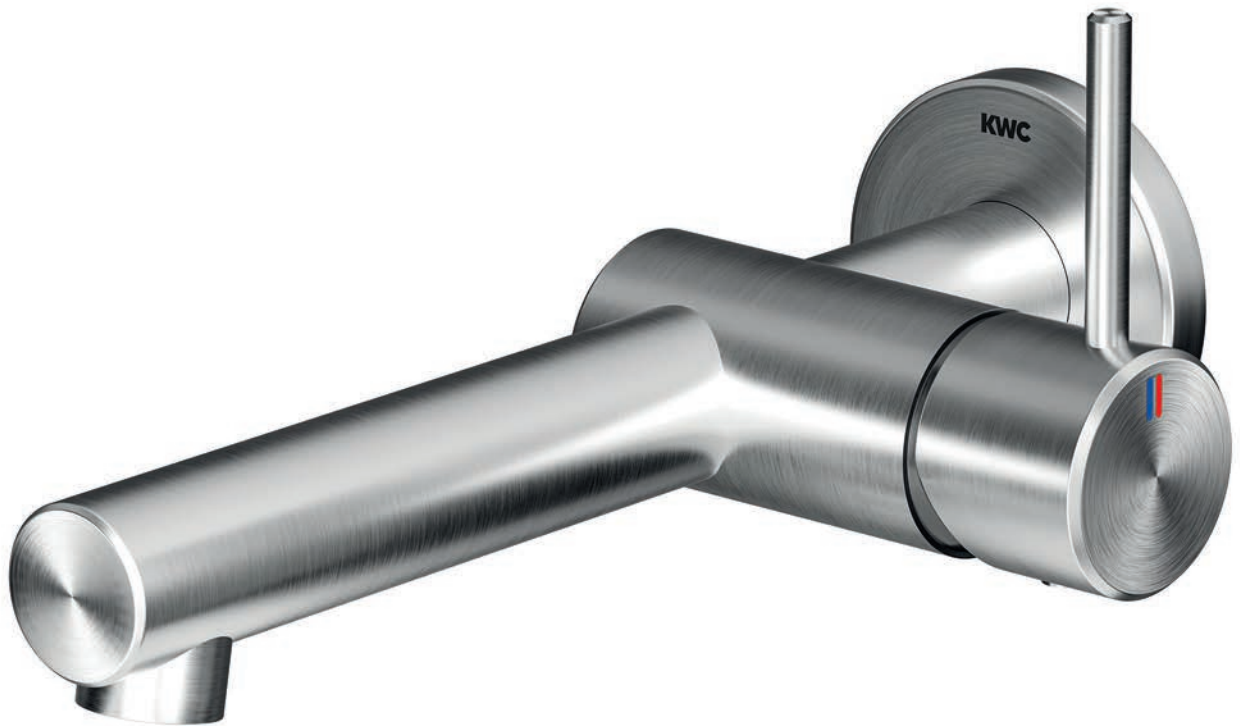

More hygiene

An aerator for greater hygiene. The aerator can be adjusted by 7° in all directions. Less splashing water means easier cleaning and better hygiene.

More space

The operating lever hovers directly above the washbasin. This helps to avoid water and limescale residues outside the washbasin. The result is cleanliness and plenty of space for your hands.



More movement

Plenty of hand clearance with low overall height. The special design enables convenient operation and adapts to requirements. The swivel spout has a radius of 120° and can alternatively also be fixed.



Mobile and practical

The aerator is adjustable and almost invisible. For cleaning, simply unscrew and descale separately. The characteristically tall, arched lever mixer provides great freedom of movement in the basin and sets visual highlights in the bathroom.

Versatile and durable

The KWC ONO E is a complete range with a variety of options for every application in the premium bathroom. Everything is exquisitely finished and seamlessly rounded. Quality and durability are absolutely top class thanks to the high-quality stainless steel.

KWC ONO E

Highlights of the features

Intuitive and elegant

A switch button for the spout and handheld shower directly on the mixer ensures effortless operation. Functional and streamlined – stylish down to the last detail.



Natural and safe

The cascade spout acts like a small waterfall in the bath. It's easy to clean. The design and mounting help to prevent unintentional impact with your body.

KWC ONO E

Data for the future

High quality and sustainable

High-quality and sustainable V4A stainless steel. The highest grade of stainless steel. It provides no breeding ground for bacteria. Durable and recyclable, it is considered particularly sustainable. Additionally, water leaches out significantly fewer heavy metals from stainless steel than from other metal pipes.



Innovative simplicity

Simple control via optoelectronic sensor. The solid stainless-steel housing in a minimalist design requires no joints, gaps or seals – ideal for maximum hygiene and easy cleaning.

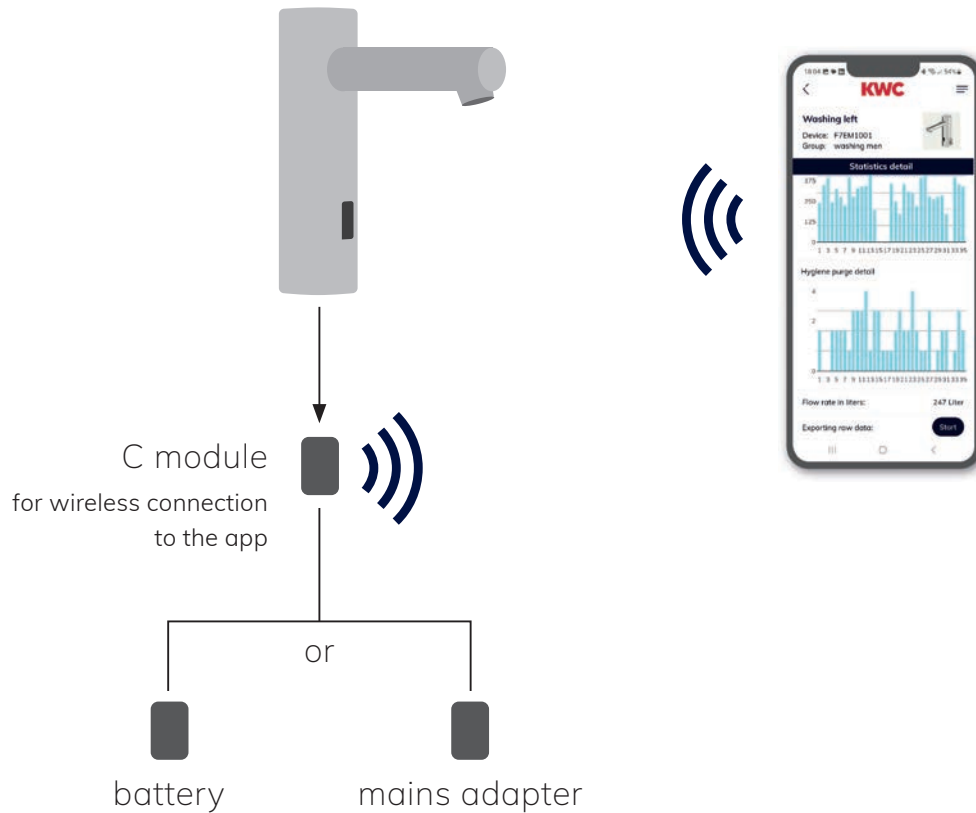

Individual and digital

Digital control guarantees simple data flow. Tips on optimising the use of the tap make it easier to save water, facilitate servicing and increase the service life of the tap. A fitting that adapts perfectly to any setting.

Modular system

What we call the connectivity module (C module) enables the fitting to be controlled and parameterised independently of the power supply via battery or mains adapter.

KWC Smart Connect app

Up to 100 fittings can be managed securely with the KWC Smart Connect app, as they are password-protected. Individual settings such as water flow time or sensor range can be parameterised.

The direct connection between the fitting and the app

The C module provides the connection between the fitting and the app. It can be connected directly to the tap cable under the washbasin using a clip integrated into the module housing.



Washbasin lever mixer
fixed spout, A115

125616, chromeline**
125617, stainless steel**



Washbasin lever mixer
fixed spout, A135

125620, chromeline**
125621, stainless steel**



Washbasin lever mixer
fixed spout, A180

125622, chromeline**
125623, stainless steel**



Washbasin lever mixer
trim kit fixed spout, A185

125634, chromeline
125635, stainless steel



Washbasin lever mixer
trim kit fixed spout, A225

125637, chromeline
125638, stainless steel



Washbasin lever mixer
swivel spout, A160

125626, chromeline*
125627, stainless steel*



Washbasin lever mixer
swivel spout, A160

125626, chromeline**
125627, stainless steel**



Pillar tap Sensor M
pre-mixed, stainless steel***

360001581, with battery
360001582, 230V



Pillar tap Sensor XL
pre-mixed, stainless steel***

360001585, with battery
360001586, 230V

* also available with Push Open 2in1, ** also available with drain fitting, *** also available with mixer tap







Shower lever mixer

125641, chromeline

125645, chromeline, AD150±20

125642, stainless steel

125646, stainless steel, AD150±20



Bathtub lever mixer

125649, chromeline

125653, chromeline, AD150±20

125650, stainless steel

125654, stainless steel, AD150±20



Bath spout A205,
square escutcheon

125659, chromeline

125660, stainless steel



Bath spout A205,
round escutcheon

125657, chromeline

125658, stainless steel



Bidet lever mixer
fixed spout, A115

125632, chromeline

125633, stainless steel

Colour variants



chromeline



stainless steel

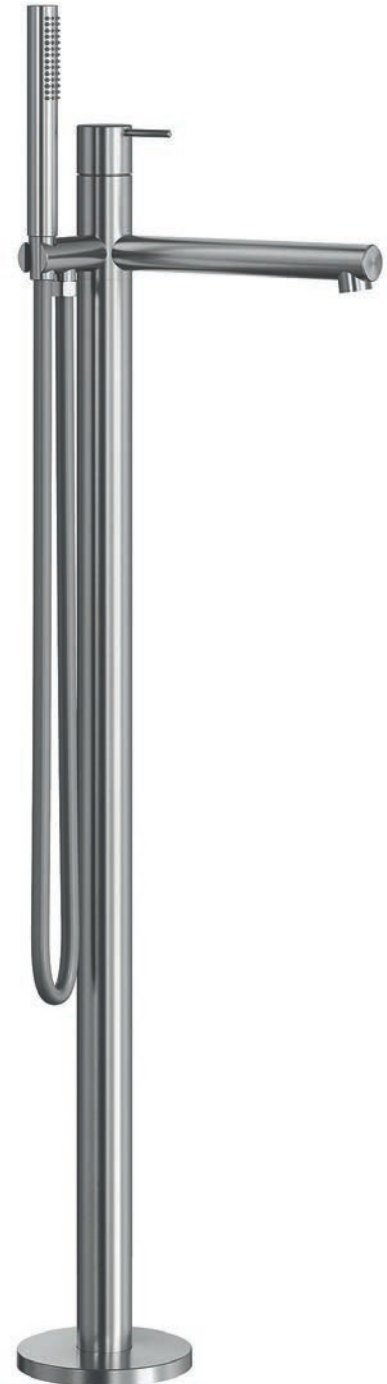

Bathtub lever
mixer A245

125655, chromeline,
with spray head and hose

125656, stainless steel,
with spray head and hose



At home in the kitchen

With a passion for detail, our kitchen taps ensure perfect harmony in the kitchen – for all the senses. The design is always elegant, the functionality ingenious – the water quality always in the foreground, filtered or unfiltered. Safe and intuitive operation, including touch-free with just a wave of your hand. The precise workmanship ensures long-lasting enjoyment of the tap. The materials and stainless steel are of the highest quality, facilitating easy cleaning and maximising hygiene. Premium quality for ambitious amateur cooks and the whole family.

The essence of function and design

KWC FIT – a tap for individual
styles and kitchens of all kinds.

The KWC FIT is characterised by its cylindrical basic shape. Its design follows its function. This makes the seamless monobody particularly easy to clean – perfect for hygiene and great for its service life. Maximum user-friendliness and variable models. As flexible as it is, it fits into any kitchen, regardless of the available space.





KWC FIT

Tangible benefits

Flexibility guaranteed

KWC FIT fits in perfectly, even in tight spaces. The tap can be conveniently operated with any type of installation. Despite its compact design, the water delivery point is always optimised.



Stylishly functional

The understated, cylindrical design enhances the look of any kitchen. The integrated, front-mounted spray head diverter offers full functionality with a slimline appearance.



Harmoniously integrated

Switching between the two jet types is as simple as the overall handling. The spray head sits perfectly in your hand. The diverter fits in visually with the design.

Easy to clean

The tap body without escutcheon is practical to clean. On models without a pull-out spray head, the aerator can be cleaned of limescale by gently rubbing the silicone screen.



Kitchen lever mixer
swivel spout, A215

125570, chromeline
125571, matt black



Kitchen lever mixer
pull-out spray head, A205

125572, chromeline
125573, matt black





Kitchen lever mixer
swivel spout, A205

125574, chromeline
125575, matt black



Kitchen lever mixer
pull-out spray head, A200

125576, chromeline
125577, matt black







Lightness in form and function

KWC BEVO E – premium stainless-steel tap with high standards of hygiene and safety.

The slim silhouette of the KWC BEVO E captivates. The transitions are strikingly elegant. As a design element, the asymmetrical spout catches the eye and brings exclusivity to the kitchen. There are practical reasons for using stainless steel, as it guarantees comprehensive hygiene, durability and a long service life. The double-shell design of the spray models ensures a high level of safety. No matter how hot the water flowing through the tap, the outer shell of the KWC BEVO E remains cool – reliable protection against scalding.

KWC BEVO E

Designed for hygiene

Quiet purity

The laminar flow of the KWC BEVO E is remarkably quiet because it flows without disturbing the surrounding air. This improves hygiene, as virtually no bacteria are absorbed from the surrounding air, and reduces the noise to a comfortable level.





Functional jet

The soft spray operating mode is suitable for gently washing fruit and vegetables. With the strong and quiet laminar stream, pots can be filled quickly and washing up is practically spray-free.

Sustainable design

The elegant KWC BEVO E interprets classic KWC design elements. Wherever it is used, it is an eye-catcher, both in the industrial black and brushed stainless steel versions. The stainless steel of the tap can be almost completely recycled and is already partially recycled – a sign of its sustainability.

KWC BEVO E

Hybrid operation

Contactless hygiene

A simple wave activates the cold water flow – completely contact-free and without leaving drops on the tap. It stops again just as automatically. Another wave and the water flows again. The sensor control of the hybrid version enables even greater hygiene in the kitchen.



Manual familiarity

Conventional control with mixed water for cold, warm and hot works as usual with a lever – practical for everyday use of the tap when washing up, filling pots and other kitchen tasks.





Kitchen lever mixer
swivel spout, A215

125589, industrial black
125343, stainless steel



Kitchen lever mixer
pull-out spout, A220

125590, industrial black
125344, stainless steel



Kitchen lever mixer
pull-out spray, A220

125591, industrial black
125345, stainless steel



Kitchen lever mixer
swivel spout, A220

125347, industrial black
125346, stainless steel



Kitchen lever mixer
pull-out spout, A225

125351, industrial black
125350, stainless steel



Kitchen lever mixer
pull-out spray, A230

125355, industrial black
125354, stainless steel



Hybrid kitchen fitting
pull-out spout, A225

3600005936, industrial black
3600005935, stainless steel

Colour variants



stainless steel



industrial black





Taps for catering professionals

Professional kitchens need to achieve optimal results at all times. The taps also need to be safe, efficient, reliable, easy to use, and robust. As a leading manufacturer of professional taps, we have many years of experience in the requirements of large kitchens, and our product solutions set standards internationally.

From the efficient lever mixer with our high-performance cartridge to the pre-rinse spray with swivel faceplate, we know what makes day-to-day tasks easier for catering professionals and offer long-lasting premium quality, hygiene and performance in one.

For catering kitchens and at home – by professionals for professionals.

The best of both worlds

KWC BISTRO E – professional quality for small catering establishments and exclusive kitchens in stainless steel.

Suitable for every situation. Genuine professional quality made of stainless steel for ambitious chefs with high standards. Design-orientated with the highflex hose or high performance with the dish spray head, the KWC BISTRO E adapts effortlessly to all requirements. Also available as a swivel version with or without sensors for the tea or coffee kitchen. Efficiency and technology for performance, easy cleaning and convenient operation. Maximum hygiene standards and convenience in amateur kitchens and small catering establishments.





KWC BISTRO E

Efficiency and technology in action

Guaranteed room for manoeuvre

The spring hose with the patented highflex technology can be rotated in all directions. This significantly extends the range of movement. The hose remains stationary when not in use. This ensures relaxed and comfortable working at and in the sink – at all times.

Dual-jet spray head

A dish spray head with convenience and great cleaning performance at the same time. The centred cleaning jet is ideal for gentle washing or filling pots. The spray jet effortlessly removes stubborn dirt.



Flawlessly robust

Stainless steel of quality grade V4A is particularly high-quality, durable and resistant to acids and chlorides. The fitting has a correspondingly long service life. It also ensures spotless hygiene, as this material is very resistant to bacteria. Perfect for the catering trade.

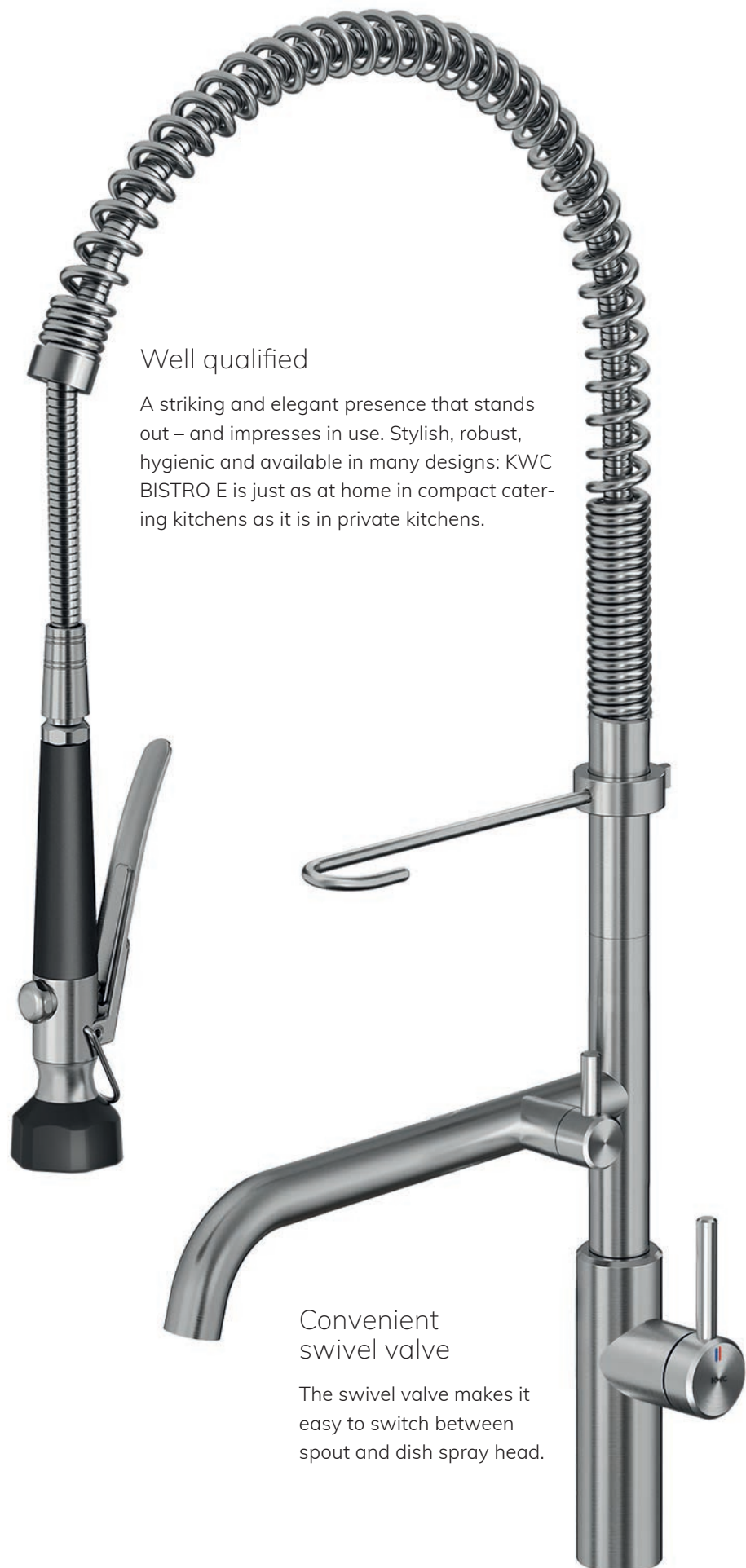

Well qualified

A striking and elegant presence that stands out – and impresses in use. Stylish, robust, hygienic and available in many designs: KWC BISTRO E is just as at home in compact catering kitchens as it is in private kitchens.

Versatile professional spray head

A locking mechanism allows free movement. A neatly integrated stainless-steel lever is used to switch between the jet modes: the needle spray is suitable for pre-rinsing and washing food. The water-saving high-pressure cleaning jet removes stubborn dirt.

Convenient swivel valve

The swivel valve makes it easy to switch between spout and dish spray head.

KWC BISTRO E

Efficiency and hygiene



Hybrid solution

Less soiling, less consumption and therefore lower costs. These are just some of the many advantages of the hybrid version of the KWC BISTRO E, which can be operated hands-free. This is hygienic and standard in washrooms in commercial and public buildings. As an electronic sensor tap, this makes it ideal for tea and coffee kitchens. As a hybrid, it combines the advantages of a sensor tap and a lever mixer. Whether with a simple hand gesture or conventionally with the lever – the pure stainless steel guarantees hygiene at all times.



Long-lasting use

The brushed stainless steel is robust and durable. It is easy to clean and resistant to bacteria – perfect for hygiene. An important bonus for the environment and health is that stainless steel leaches out significantly fewer heavy metals than other materials.

Setting the scene

The tall spout offers three adjustable swivel ranges of 50°, 120° or 360°. It can be locked in the centre position.

Everyday use

Manual control for mixed water is done with the lever. Quite simply and practically the way that makes the most sense for everyday work in the kitchen.

Progressively clean

The low-noise laminar jet does not draw in any ambient air – so no bacteria either. An important aspect for hygiene.

Always clean

One wave and the water flows as preset. Contactless and comfortable. Possibility of parameterisation and communication via an optional bidirectional remote control.



Lever mixer
swivel spout, A250

125692, stainless steel



Lever mixer highflex,
A235

125694, stainless steel



Lever mixer dish spray head,
A295 with spout

125696, stainless steel



Hybrid kitchen fitting
swivel spout, A220

3600001625, stainless steel, sensor, battery
3600001626, stainless steel, sensor, mains

Both models also available as low-pressure versions.



Always a class ahead

KWC GASTRO E – the premium stainless-steel solution for the catering industry.

True professional kitchens dazzle with fittings from the KWC GASTRO E line made of pure V4A stainless steel. This means a longer service life thanks to the acid and chloride resistance, higher hygiene standards, greater safety and sustainability – also thanks to the extremely robust material.

The KWC GASTRO E line range is extensive. The variants can be combined and expanded with extension elements for any application. Another highlight is the robust dish spray with swivelling faceplate for maximum ease of use.





KWC GASTRO E

Premium in every detail



Innovative operation

The faceplate can be angled by 45° with a simple flick of the wrist. Maximum convenience in the professional kitchen and a genuine innovation from the KWC brand.

Rewarding care

The dish spray can be shut off for cleaning. It features delayed closing for pressure shock damping, and a valve maintenance unit. This ensures that the tap can be reliably maintained, which in turn helps increase its service life.



Unbeatable advantages

Cleaning is easy and hygiene is excellent because stainless steel does not provide a breeding ground for bacteria. Stainless steel is durable, robust, leaches out virtually no heavy metals and can be fully recycled – ex works sustainability included.

Individual optimisation

Two different base lengths allow the tap height to be adjusted. The flexible connection hoses simplify and speed up installation. The 360° swivel range rounds off the ease of use perfectly.

A durable solution

The soft packing between the spout and the body is made of hemp. When in use, humidity expands the plant fibre, and only then is the nut tightened. For a perfect seal, simply retighten the nut slightly.

A practical detail

A simple solution called Drip-Stop. The optional accessory reliably prevents water from dripping. Particularly useful if the tap is positioned close to the hob.

KWC GASTRO E

Premium quality from Unterkulm

True top performance

The KWC high-performance cartridge impresses with an exceptionally high flow rate – premium in everyday life, quality for decades, made by KWC.



Easy cleaning

The dish spray can be dismantled to clean or replace the valve and spray individually.



Dual-jet all-rounder

The water-saving dish spray offers two jet types. The conical cleaning jet is ideal for gentle washing, the high-performance jet for heavy soiling. The faceplate is adjustable, which makes work easier and protects the spray hose.



Lever mixer
swivel spout, A300

125565, stainless steel



Lever mixer
swivel spout, A450

125566, stainless steel



Lever mixer
dish spray, A200
with spout

125567, stainless steel



Lever mixer
dish spray, A300
with spout

125568, stainless steel



Extension base
100 mm

539000, stainless steel



Extension base
300 mm

539001, stainless steel



Dish spray,
swivel

539030, graphite grey



Imprint

Publisher

KWC Group AG
KWC-Gasse 1
CH-5726 Unterkulm
T +41 41 62 768 69 00
info@kwc.com

Managers

Frank Schnatz (CEO)
Florian Lehmann (CSO)
Viktor Bernhardt (CFO)

Responsible for content
Florian Lehmann

Commercial register court:
Feldkirch Commercial Court
UID reg. no. ATU 67293458
Company register no.: FN 380201 w

Copyright

All rights reserved.
Articles may only be reprinted with the written permission of KWC Group AG and with precise reference to the source.
We reserve the right to make technical modifications to the design of the products.
Colour deviations due to printing are possible.

Idea and concept

tkhd GbR
Strähuberstraße 18
81479 Munich, Germany

Implementation

MGgrafik, Maren Graebe
Am Sportplatz 6
83098 Brannenburg, Germany

Picture credits

page 05: Jasmin Lorvik (Nordic Villa),
pages 22 – 23: Jasmin Lorvik (jasmin88k),
page 25: Lukas Lienhard (Schloss Schauenstein),
pages 26 – 27: Anna Spencer Photography,
pages 28 – 29: Lukas Lienhard,
pages 30 – 31: Lukas Lienhard,
pages 32 – 33: ChristianBeeck.de, Sascha Klahn,
pages 34 – 35: ChristianBeeck.de,
pages 36 – 37: Viva con Agua

All other figures: KWC Group AG

Errors and technical modifications reserved.

KWC



KWC

Eingang ↑



The ultimate
choice